

Columbia University, Dept. of Electrical Engineering		(C) 2003
Title: PCI INTERFACE		
Size: B	Document Number: PCIDDR SCHEMATICS	Rev: AX01
Date: Wednesday, December 03, 2003	Sheet: 1	of 5

5

4

3

2

1

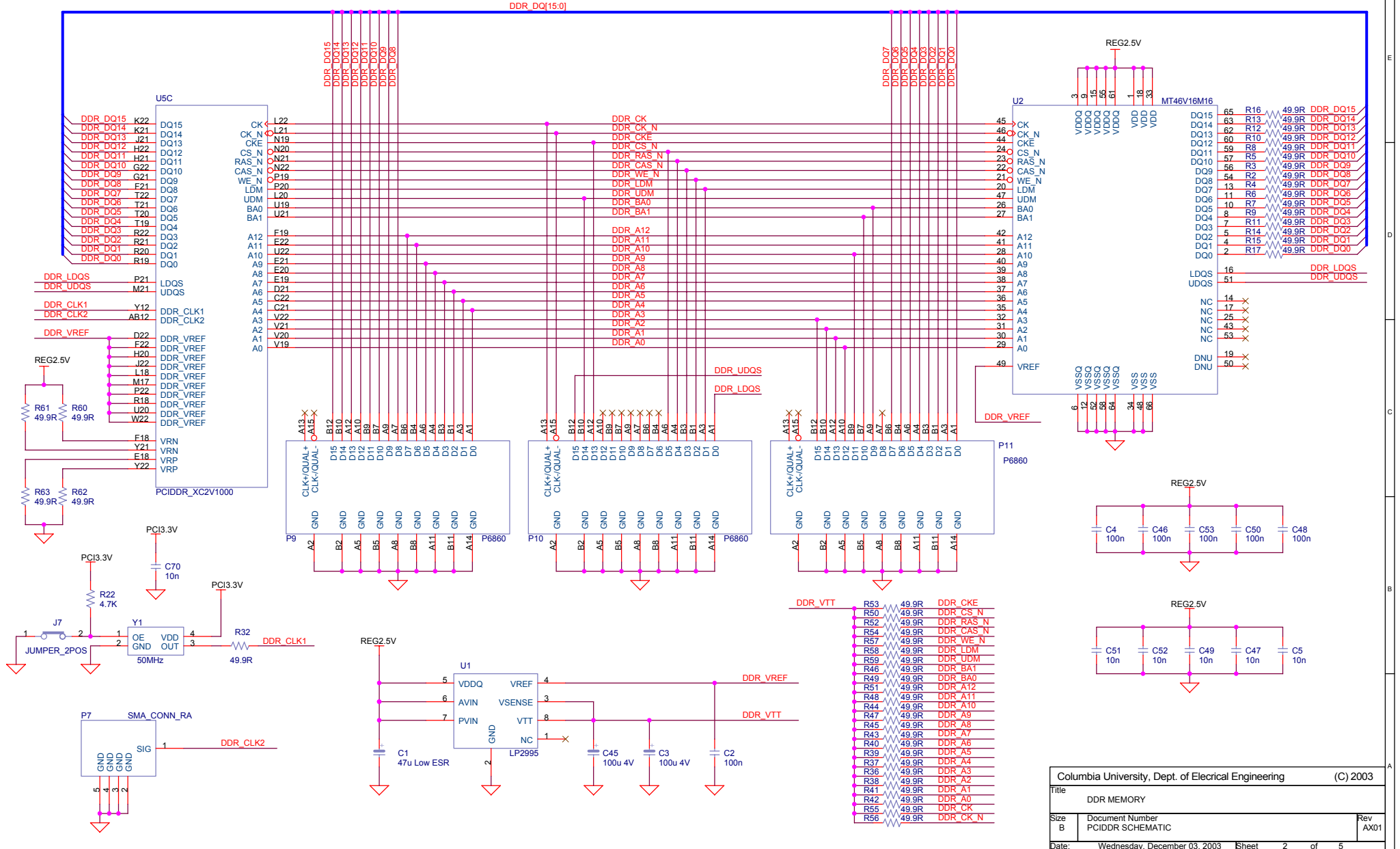

TO BE DISPLAYED IN TOP SILKSCREEN:

- 1 - POWER
- 2 - TDI
- 3 - TMS
- 4 - TCK
- 5 - TDO
- 6 - GND

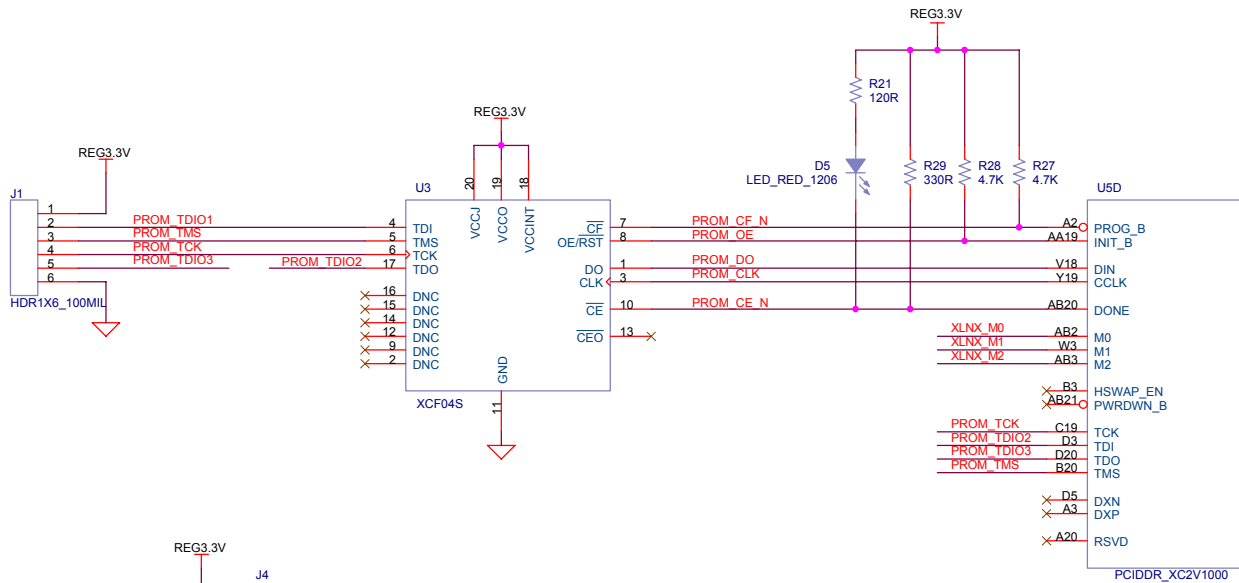

TO BE DISPLAYED IN TOP SILKSCREEN:

XILINX CONFIG MODE PINS:
 MASTER SERIAL = '000'
 JTAG = '101'

JUMPERED = LOGIC '1'
 EMPTY (OPEN) = LOGIC '0'

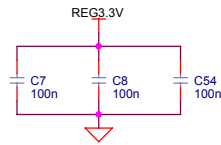
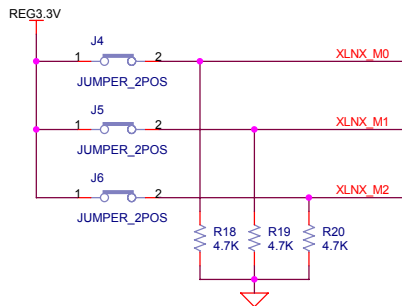

Columbia University, Dept. of Electrical Engineering		(C) 2003
Title XILINX CONFIGURATION PROM		
Size B	Document Number PCIDDR SCHEMATIC	Rev AX01
Date:	Wednesday, December 03, 2003	Sheet 3 of 5

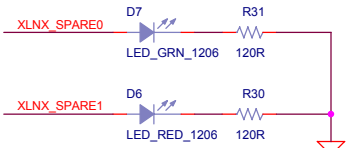
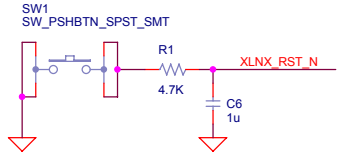

GROUND CONNECTIONS FOR PROBING

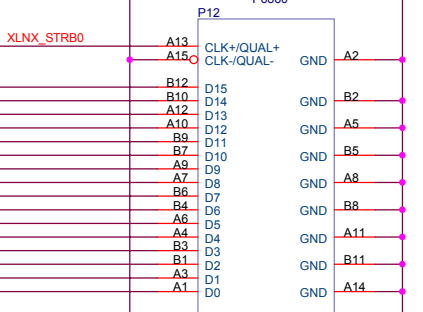
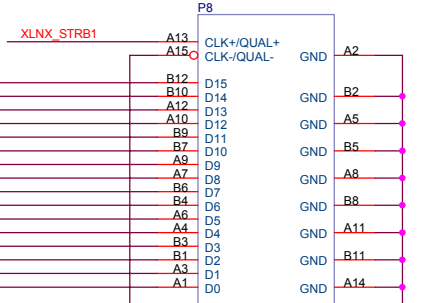
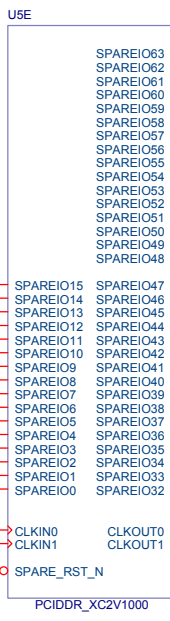
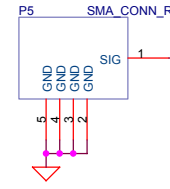
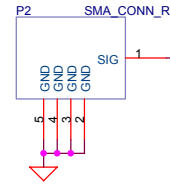
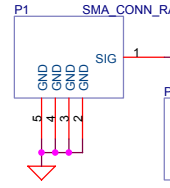
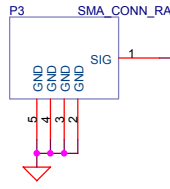
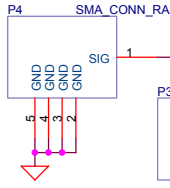
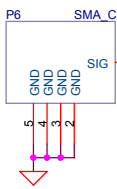
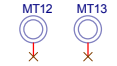
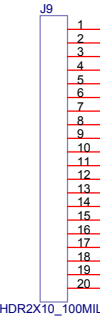
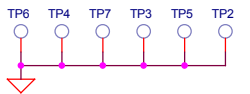

Columbia University, Dept. of Electrical Engineering		(C) 2003
Title TESTING/DEBUG INTERFACE AND TDR LAB		
Size B	Document Number PCIDDR SCHEMATIC	Rev AX01
Date: Wednesday, December 03, 2003	Sheet 4	of 5

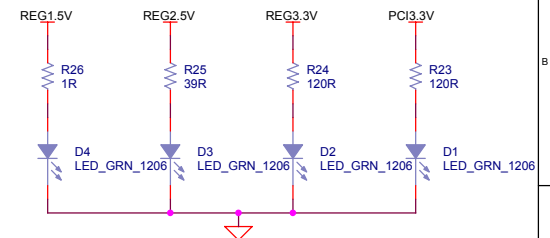
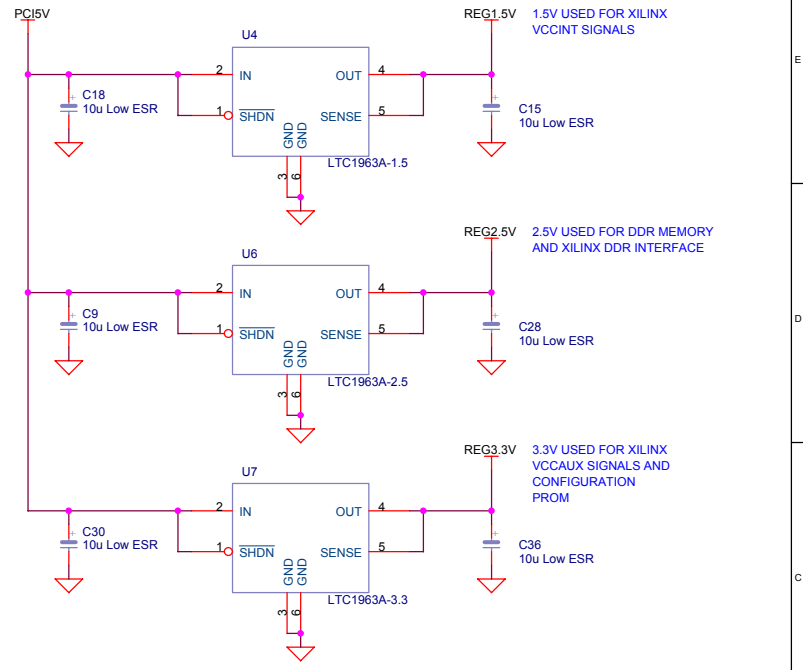
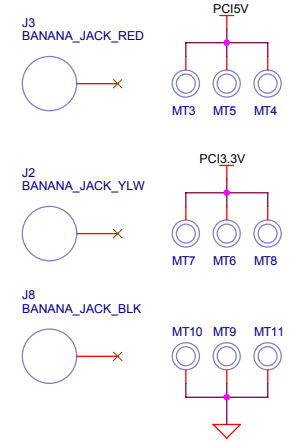
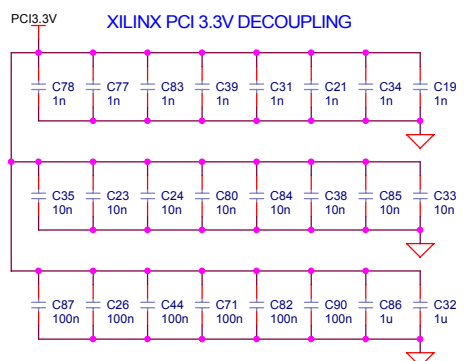
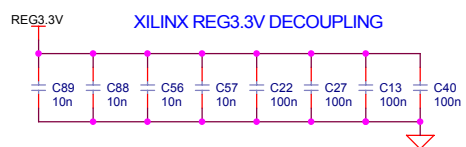
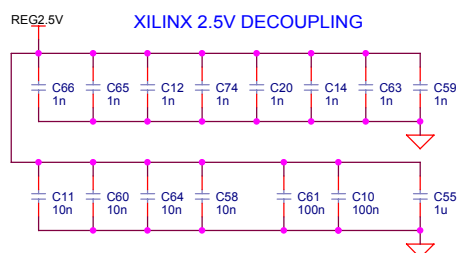
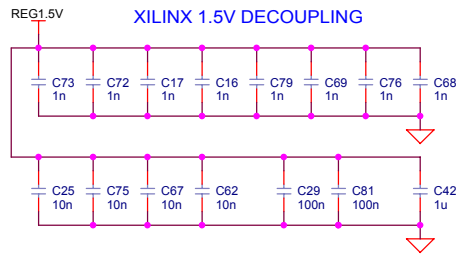
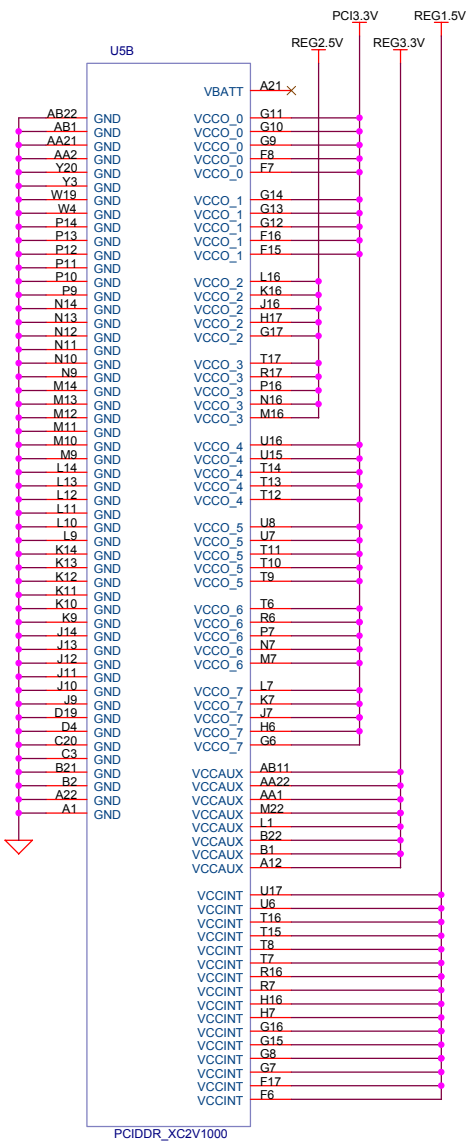

Columbia University, Dept. of Electrical Engineering		(C) 2003
Title POWER AND DECOUPLING		
Size B	Document Number PCIDDR SCHEMATIC	Rev AX01
Date: Wednesday, December 03, 2003	Sheet 5	of 5